



[ AIS SART ]

PLOMO-500



USER MANUAL





## **COPYRIGHT**

The entire contents of this instruction manual, including any future updates, revisions, and modifications, shall remain the property of AMEC at all times. Unauthorized copies or reproduction of this manual, either in part or whole, in any form of print and electronic media, is prohibited. The contents herein can only be used for the intended purpose of this manual.

## **DISCLAIMER**

AMEC is devoted to publish and maintain this product manual. As we continue to improve our AIS products to satisfy all customers' needs, information in this document is subject to change without notice. AMEC does not make any representations or warranties (implied or otherwise) regarding the accuracy and completeness of this document and shall in no event be liable for any loss of profit or any commercial damage, including but not limited to special, incidental, consequential, or other damage.

## **Contact us at:**

### **Technical Support:**

(Your Local Dealer/Agent Warranty Stamp)

### **Sales & Marketing:**

#### **ALLTEK MARINE ELECTRONICS CO., LTD**

14F-2, NO. 237, Sec.1, Datong Road, Xizhi District, New Taipei City 22161, Taiwan

TEL: +886 2 8691 8568

FAX: +886 2 8691 9569

[www.alltekmarine.com](http://www.alltekmarine.com)

Version 1.25

## WARNING!

The equipment said in this manual must only be used to which it was designed. Improper operation or installation may cause damage to the equipment or injury to personnel. AMEC will not incur any liability of equipment damage or personal injury due to improper use or installation of the equipment. It is strongly recommended to read this manual and the following safety instructions before proceeding to installation or operation.

## SAFETY INSTRUCTIONS

### WARNING



**ELECTRICAL SHOCK HAZARD.**  
Do not open the case of the equipment. Only qualified personnel could work on the interior of the equipment.

**TURN OFF THE POWER IMMEDIATELY IF WATER LEAKS INTO THE EQUIPMENT OR OBJECT DROPS INTO THE EQUIPMENT.**

Continue operating the equipment could cause electrical shock or fire. Contact your nearest distributor for service.

**DO NOT DISASSEMBLE OR MODIFY THE EQUIPMENT.**

Improper disassemble or modification could cause electrical shocks, fire, or personal injury.

**AVOID OPERATING THE EQUIPMENT WITH WET HANDS.**

Electrical shocks could be resulted if operating with wet hands.

### WARNING

**TURN OFF THE POWER IMMEDIATELY IF THE EQUIPMENT IS EMMITTING SMOKE OR FIRE.**

Continue operating the equipment could cause electrical shock or fire. Contact your nearest distributor for service.

**EVEN THOUGH THE EQUIPMENT IS WATERPROOF, PLEASE AVOID DIRECT CONTACT WITH RAIN OR SPLASHING WATER.**

Electrical shock or fire could be resulted if water leaks into the equipment.

**DO NOT PLACE ANY LIQUID-FILLED CONTAINER ON TOP OF THE EQUIPMENT.**

Electrical shocks could be resulted if the device is contaminated with liquid.

**DO NOT CUT, SHORTEN OR LENGTHEN THE SUPPLIED CABLES BY AN APPROPRIATE SUPPLIER.**

Improper change of cable length and connector could cause failure of transmitting signal.



## **FORWARD**

Congratulations on the purchase of PLOMO-500 AIS SART. PLOMO-500 is strictly tested to meet the rigorous demands of the marine environment. Unless improper use, installation, or maintenance, the equipment should function properly at its optimum.

The operation instructions contained in this manual is applied only to PLOMO-500. AMEC and the authorized local agent/dealer will not bear any responsibilities of damages resulted from improper installation by any unauthorized agent/dealer.

**We thank you for choosing our product and we wish you a bon voyage.**





## Table of Contents

- 
- I. COPY RIGHT & DISCLAIMER
  - II. WARNING & SAFETY INSTRUCTION
  - III. FORWARD

	Page
<b>1 AMEC AIS SART PLOMO-500 Introduction .....</b>	<b>7</b>
1.1 AIS SART Brief .....	7
1.2 PLOMO-500 Overview .....	8
<b>2 INSTALLATION .....</b>	<b>9</b>
2.1 Items in the Package .....	9
2.2 Mounting .....	10
<b>3 OPERATION .....</b>	<b>11</b>
3.1 Emergency .....	11
3.1.1 Deployment Process .....	11
3.1.2 Activating Process .....	12
3.1.3 Mounting Process .....	13
3.1.4 De-activating Process .....	14
3.2 Self-Test .....	15
3.2.1 Before Testing:.....	15
3.2.2 Start Testing .....	15
3.2.3 Description of TEST LED.....	16
<b>4 Importance .....</b>	<b>17</b>
4.1 GPS Area.....	17
4.2 Reception by AIS receiver .....	17
4.3 Maintenance.....	18
4.4 Replacement .....	18
4.5 Battery Disposal .....	18
<b>5 APPENDIX.....</b>	<b>19</b>
5.1 Product Specifications.....	19
5.2 Dimensions .....	21
<b>6 AMEC WORLDWIDE WARRANTY .....</b>	<b>23</b>
<b>7 DECLARATION OF CONFORMITY .....</b>	<b>25</b>



# 1 AMEC AIS SART PLOMO-500 Introduction

## 1.1 AIS SART Brief

AIS SART is the latest SART (**S**earch **A**nd **R**escue **T**ransponder/Transmitter), designed for survivor location during search and rescue operations. From 1<sup>st</sup> of January 2010, AIS SART has been adopted into the GMDSS (Global Maritime Distress Safety System, Figure 1.1) regulations as an alternative to the traditional SART equipment, RADAR SART.

AIS SART provides more identification, such as position rather than RADAR SART during search and rescue operation period. The transmitting frequency has been set as 161.975MHz & 162.025MHz in marine VHF channel. AIS SART combines two antennas, GPS and VHF, which allows transmitting its latitude and longitude, message 1 and message 14 to AIS station.

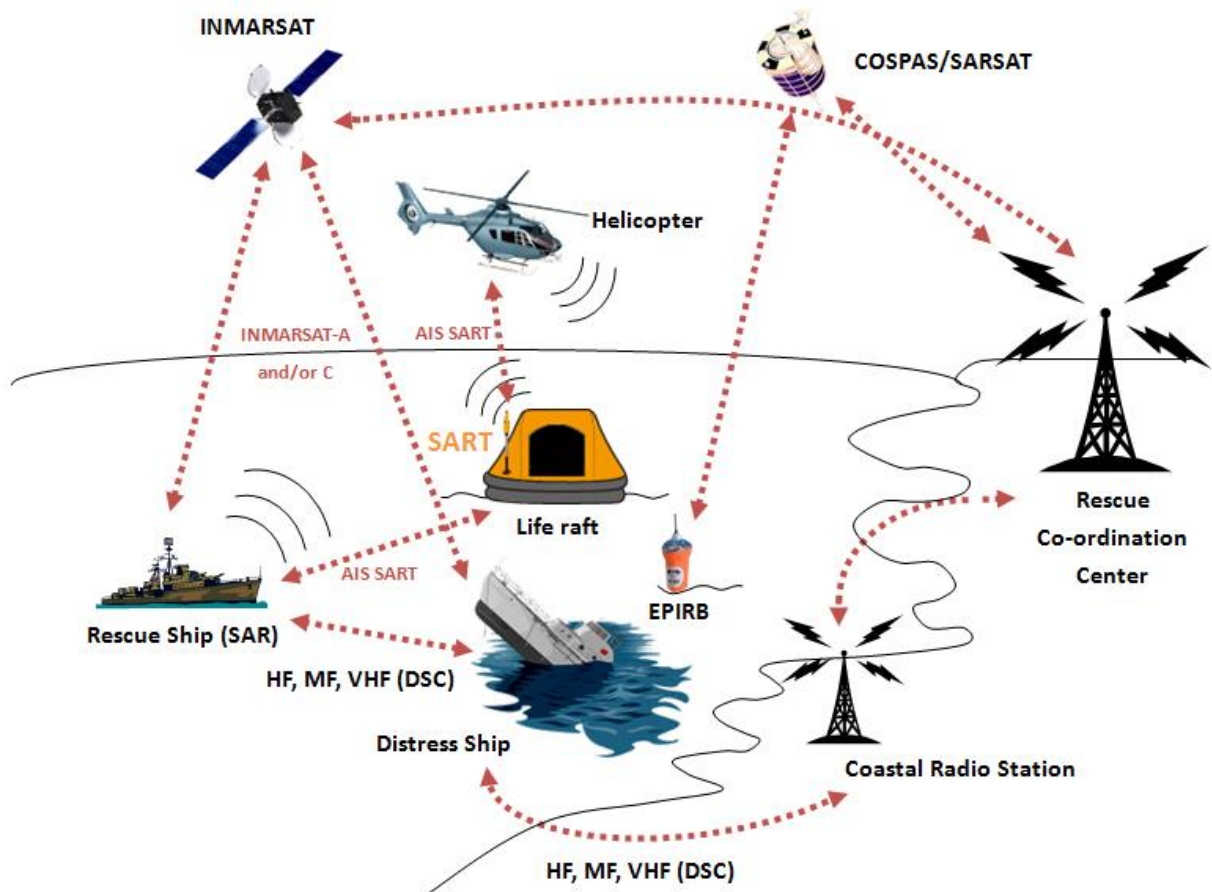

Figure 1.1 SART in Global Maritime Distress Safety System (GMDSS)

## 1.2 PLOMO-500 Overview

AMEC has launched newly AIS SART, PLOMO-500 which builds in the latest technology of GPS receiver, sophisticated power-saving circuits design, lighter weight and easier installation and operation.

Besides, PLOMO-500 provides the most user-friendly interface and allows crews or passengers to shorten their operation time to transmit their location and SRM (Safety Related Message) to any other AIS receiver device.

The key features of PLOMO-500 shows as follows:

### Handing:

PLOMO-500 is designed for easy operation. It has a carry bag which contains all main body, 1 meter extension pole and 10 meters buoyant lanyard. The carry bag can be mounted and hanged in the ship by wall-mount bracket. Users can easily understand the instruction printed on the main body and bag in a very short time.

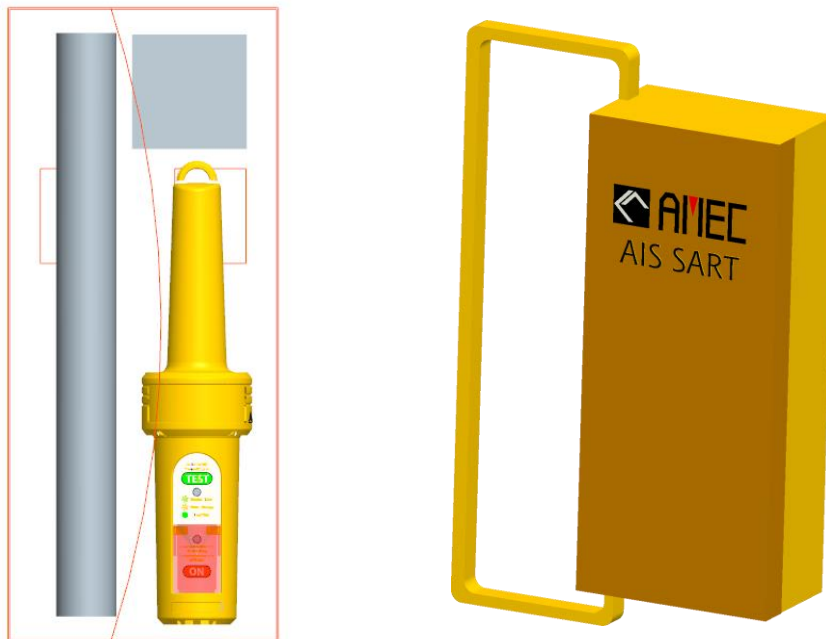

Figure 1-2 Carry bag of PLOMO-500

### Robust & Waterproof Design

PLOMO-500 has been tested for more than 10 meters deep of water resistant and dropped in the water from 20 meters without damage. Besides, it can be buoyant on the water and resist to seawater, oil and sunlight.



### Viewable Panel Design

PLOMO-500 has florescent backlight panel which allows users can read the operation button and active button in twilight environment. Aside from that, the Flashing of Active mode is coding in Morse Code “SOS” which is viewable in dark environment as well.

### Easy Installation

The additional extension pole can extend length up to 1 meter and user only need to connect and rotate with PLOMO-500 and extend pole to 1 meter.

## 2 INSTALLATION

### 2.1 Items in the Package

The PLOMO-500 is typically delivered with standard package as shown in Table 2-1. It is also illustrated in Figure 2-1 (except manual).

**Table 2-1 Standard equipment list**

No.	Description		Qty
1	AMEC PLOMO-500 AIS SART		1
2	Manual		1
3	Installation Kit	Carry Bag	1
		1M Extension Pole	1
		10M buoyant lanyard	1
		Wall-Mount Bracket	1
		Screw M4x20	4

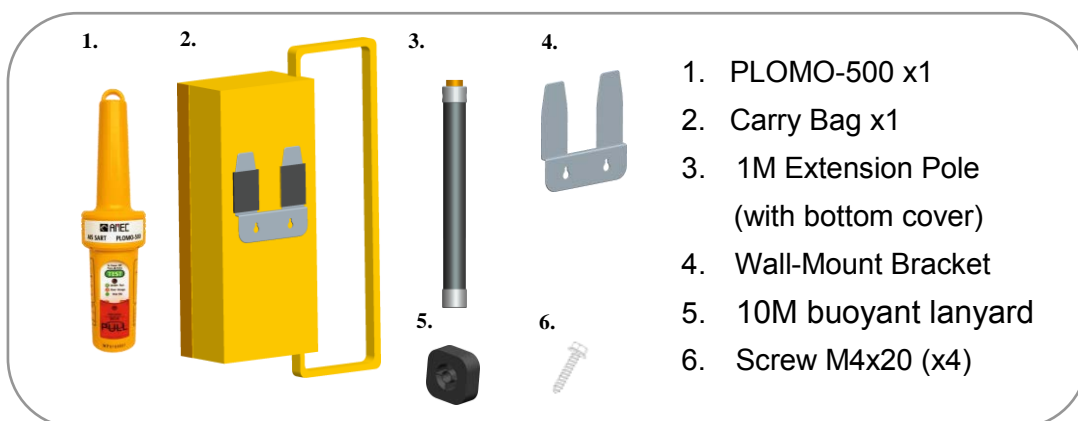

**Figure 2-1 Standard package**

## 2.2 Mounting

The PLOMO-500 is recommended to be mounted in a flat wall. The location should be follow the below instruction.

- A. Place the carry bag in visible location.
- B. Spare enough space for taking carry bag out.
- C. Fix screws on the wall tightly.

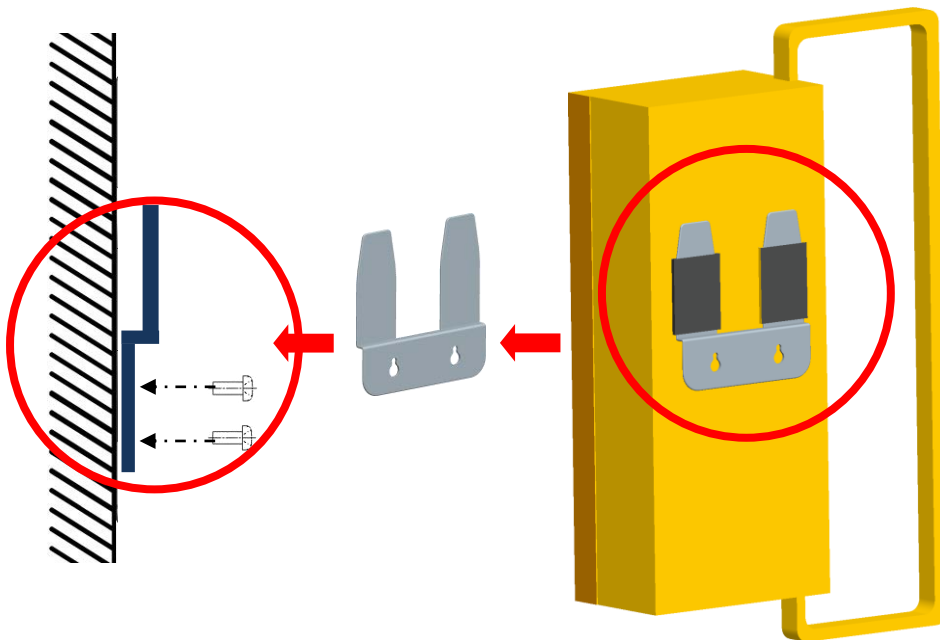

Figure 2-2 Wall mounting

### **Step 1:**

Take out Bracket from Carry Bag.

### **Step 2:**

Place Bracket on the proper flat & robust wall surface for installing.

### **Step 3:**

Use the 4 M4×20 screws to screw wall-mount bracket into the wall.

### **Step 4:**

Make sure the screws are fixed on the wall tightly and place Carry Bag into Bracket.

### 3 OPERATION

#### 3.1 Emergency

There are three major steps, Deployment, Active and Mounting, which has to be followed as below in emergency situation.

##### 3.1.1 Deployment Process

**Step 1:**

Lift Carry Bag out of bracket on the wall.

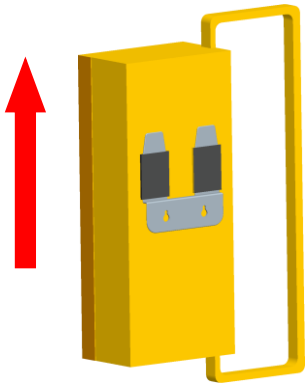

**Step 2:**

Bring Carry Bag and jump into a Life Boat.



**Step 3:**

Open Carry Bag and take AIS SART, Extension Pole and buoyant lanyard out

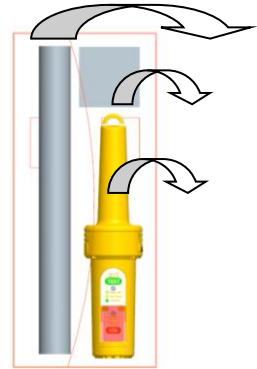

**Step 4:**

Connect and rotate extension pole into PLOMO-500.



**Step 5:**

Remove the bottom cover and extend pole up to 1 Meter



Figure 3-1-1 Deployment process

### 3.1.2 Activating Process

The PLOMO-500 unit can be activated by following steps:

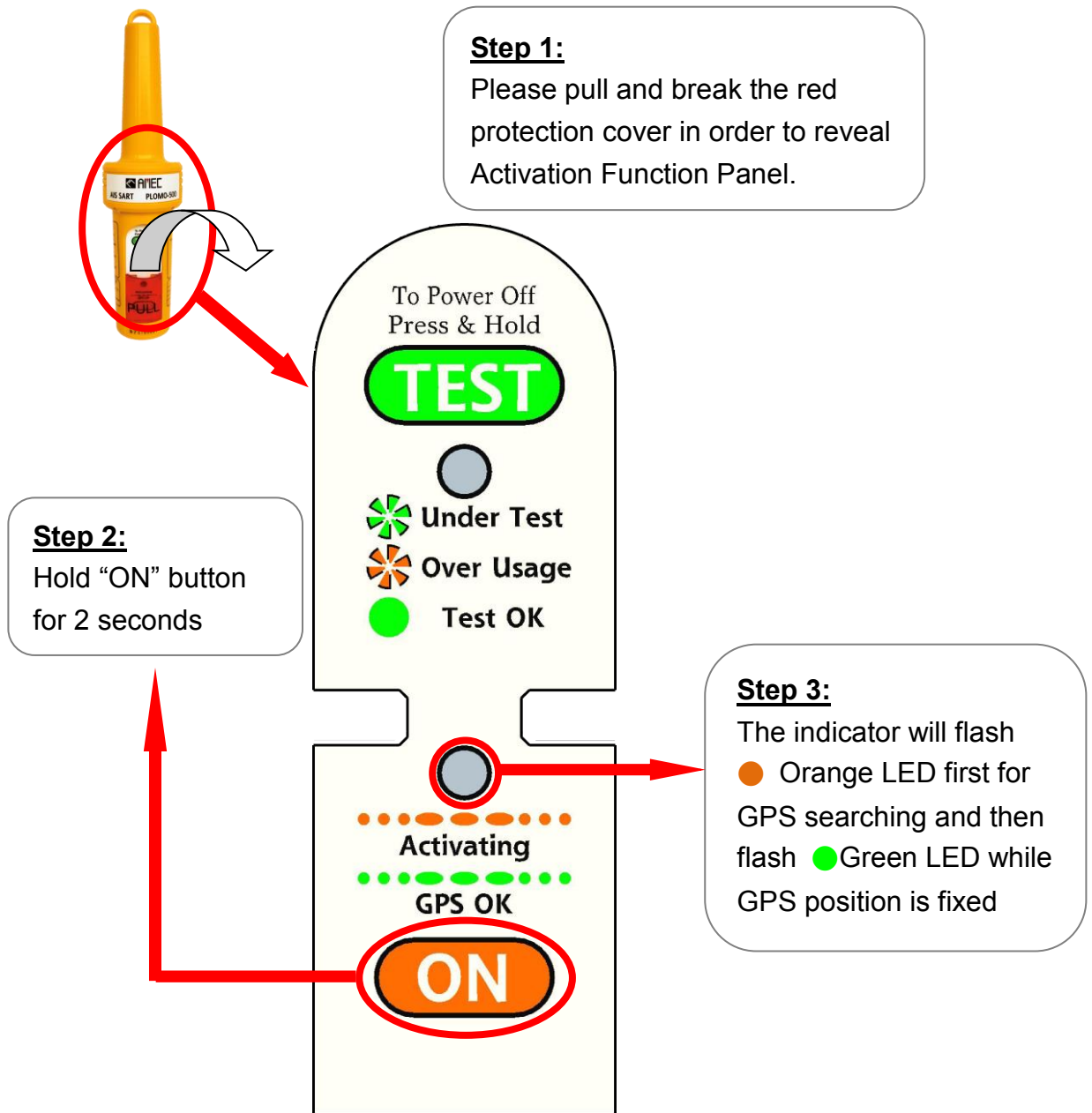

Figure 3-1-2 Activating process

**NOTE1:** The GPS receiver in PLOMO-500 will be activated (cold start) while pressing the ON button.

**NOTE2:** The LED flashing is compiled by Mores-code "SOS" every 30 seconds. PLOMO-500 will transmit SRM with the latest GPS fixed position every 1 minute. The Green or Orange LED of indicator depends on whether GPS position is fixed.

**NOTE3:** The protection cover cannot be re-installed once pulled out and broken. For cover and battery replacement, please refer to Section 4.4 Replacement.

### 3.1.3 Mounting Process

#### Installation Method 1

**Step 1:**

Release buoyant lanyard and tight at hook of PLOMO-500.



**Step 2:**

Fix and position PLOMO-500 at the top of Life Boat.

#### Installation Method 2

**Step 1:**

Connect and rotate extension pole to PLOMO-500 and extend pole up to 1 meter.



**Step 2:**

Find the doorway entrance and locate the pole in vertical position at Life Boat.

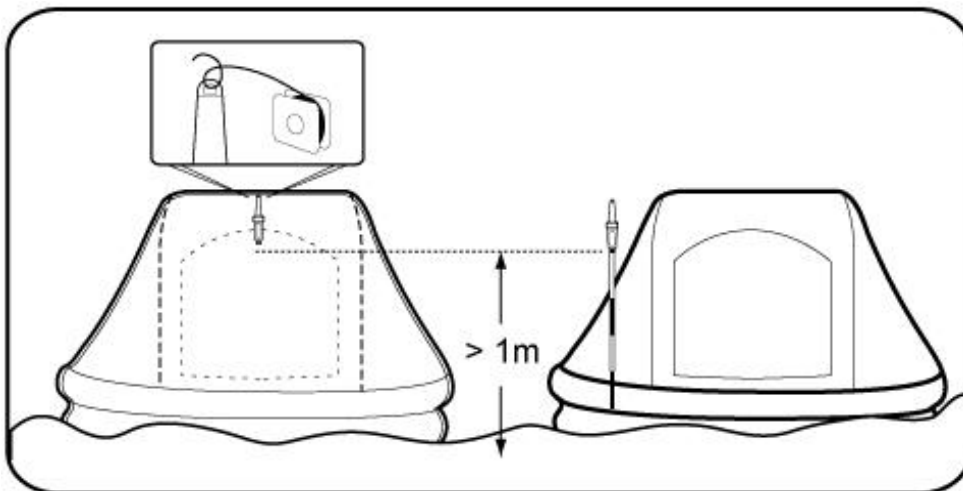

Figure 3-1-3 Mounting process

**NOTE:** In both installation methods, the PLOMO-500 unit should be kept at least 1 meter above sea level. Generally, method 2 is more effective for transmitting AIS signals.

### 3.1.4 De-activating Process

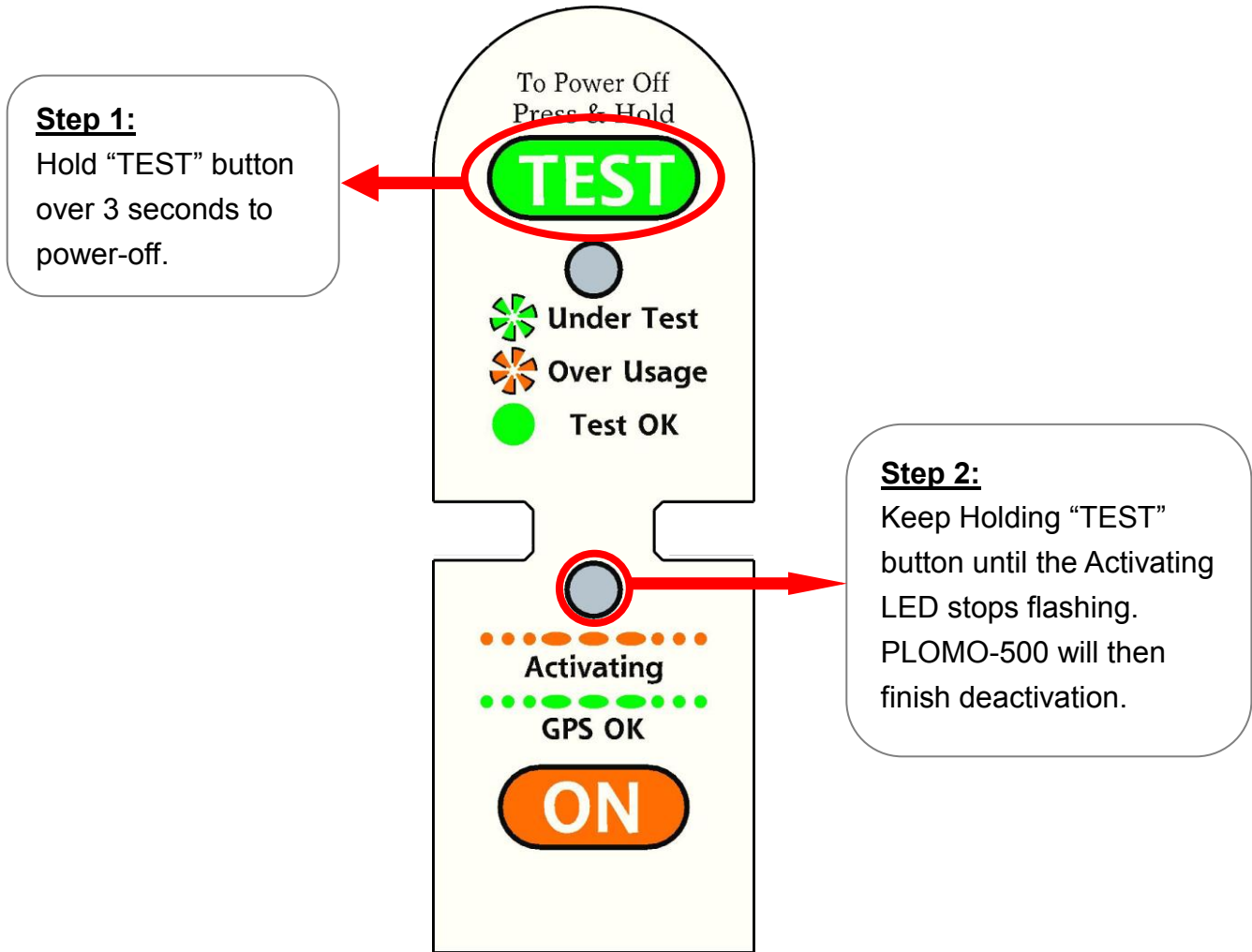

Figure 3-1-4 De-active process

**NOTE:** After de-activating, all indicators will be off-lighting status.

If the LED is still flashing, try to press "TEST" button longer than 3 seconds to de-activate the unit again.



### 3.2 Self-Test

#### 3.2.1 Before Testing:

PLOMO-500 must be carried in an open area with a clear view of the sky. For checking the testing message received by AIS receiver, please refer to Section 4.2.

#### 3.2.2 Start Testing

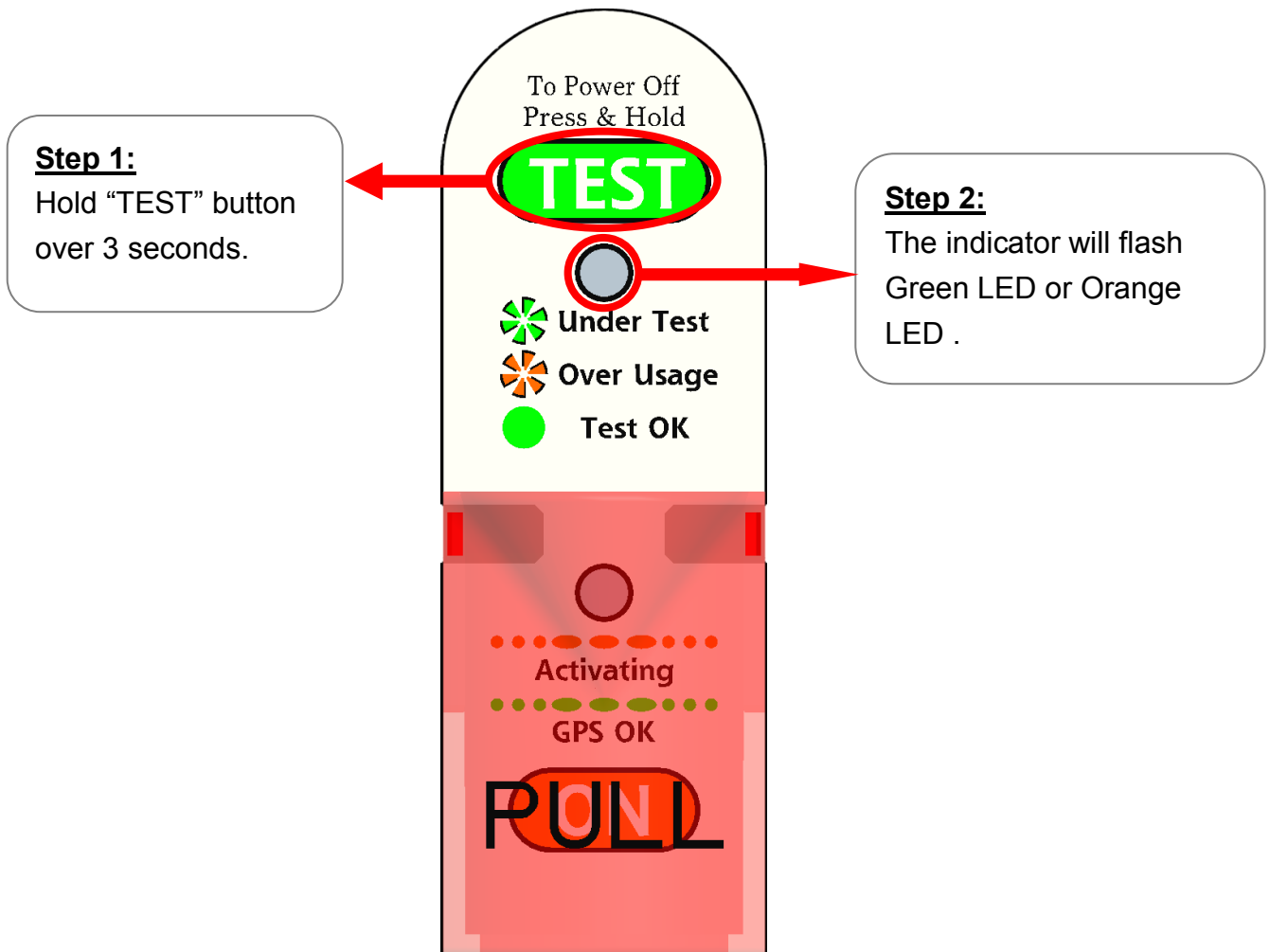

Figure 3-2-2 Start testing

**NOTE 1:** Normally the green flashing will happen in 2 mins right after the GPS position is fixed. If it happens at the 5th minute, the SART message will be transmitted automatically, and GPS position might not be fixed. Please move PLOMO-500 to other place which has a clear view of the sky.

**NOTE 2:** Orange flashing means the PLOMO-500 has been activated or tested over 100 times.



### **3.2.3 Description of TEST LED**

Green color flashes: PLOMO-500 is under testing without over usage warning

Orange color flashes: PLOMO-500 is in under testing with over usage warning

One long Green color flash: PLOMO-500 complete transmission and light-off after long green color flash automatically.

**NOTE 1: “Over usage” is caused by the following three situations: battery is out of expiry date, unit has been tested over 100 times, and unit has been activated before.**

**NOTE 2: If the green or orange color is flashing over 3 minutes, GPS position may not be fixed. It is highly recommended to move PLOMO-500 to other place which has a clear view of the sky.**

## 4 Importance

### 4.1 GPS Area

Please do not hold or cover GPS Area while active or test. It will cause the GPS 3D position fixed fault.



Figure 4-1 GPS Area

### 4.2 Reception by AIS receiver

Under active or test mode, each PLOMO-500 will transmit message with unique 9 digital ID number-970XXYYYY, position in latitude and longitude to AIS receiver. The AIS receiver will show "SART TEST" under Test Mode or "SART ACTIVE" under Active Mode.

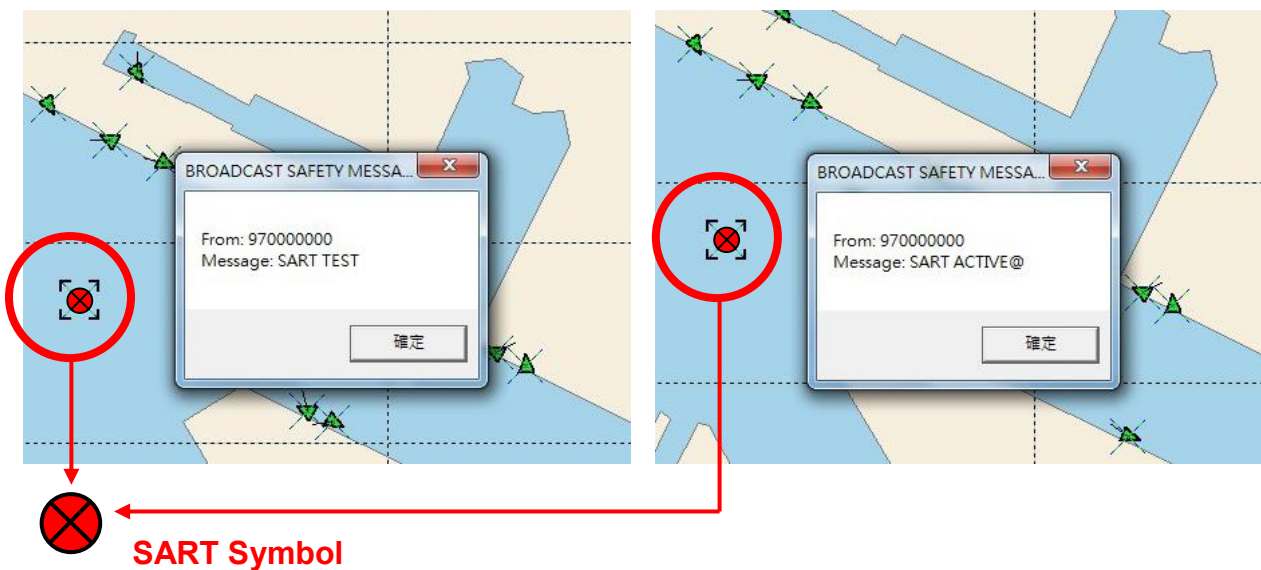

Figure 4-2 Reception by AIS receiver



### **4.3 Maintenance**

It is highly recommended to check PLOMO-500 routinely. Please check physical of PLOMO-500 whether the battery is out of expiry date, any damage of main body, wall-bracket, carry bag, extension bar, buoyant lanyard of package. For clean purpose, do not use any chemical liquid but fresh water to clean and then wipe dry.

As for functionality-test, more frequent self-testing will consume more energy of battery. Therefore, the proper periodic self-test of PLOMO-500 should follow Chapter 3.2 every 6 months.

### **4.4 Replacement**

#### **Battery**

Since the battery of PLOMO-500 is one-time used primary Lithium battery, it is not rechargeable. The battery unit should be replaced if PLOMO-500 has been activated, or test mode has been operated for a cumulative period in excess of 10 times. Also, it should be replaced every 5 year due to the battery life. The battery replacement must be done by local service Agent.

#### **Red Protection Cover**

The Red Protection Cover will be broken after pull-to-break. The replacement of Red Protection Cover must be done by local service Agent.

### **4.5 Battery Disposal**

The battery must not be incinerate in any time. As for disposal, please check local regulation first. Generally, end-users should dispose of them through non-profit organization, mandated by local governments or organized on a voluntary basis by professional. Lithium batteries should have their terminals insulated prior to disposal.



## 5 APPENDIX

### 5.1 Product Specifications

#### APPLICABLE STANDARDS

---

IEC 61097-14  
IEC 60945  
IEC 61108-1  
ITU-R M.1371  
MSC.246(83)

#### VHF TRANSMITTER

---

Operating Frequency	AIS 1, 161.975MHz AIS 2, 162.025MHz
Data Rate	9,600bps
Bandwidth	25 KHz
Power Output	1W EIRP
AIS Message Type	Message 1, Message 14
Modulation	GMSK
Antenna	Integrated by PCB

#### GPS RECEIVER

---

Receiving Channels	48 channels
Acquisition Sensitivity	(-)159 dBm
Tracking Sensitivity	(-)159 dBm
Position Accuracy	< 2.5 m Autonomous & SBAS

#### BATTERY

---

Type	Primary Lithium (not rechargeable)
Operating Life	96 hours minimum
Storage	5 years
Service	Replaceable *

\*Please refer to Section 4.4 Replacement



## **CARRY & MOUNTING**

---

**Carry Bag  
Wall Mount**

## **ENVIRONMENT**

---

<b>Operating Temperature</b>	<b>-20°C~55°C</b>
<b>Storage Temperature</b>	<b>-30°C~70°C</b>
<b>Waterproof</b>	<b>Immersion to 10m</b>
<b>Buoyancy</b>	<b>Floats</b>
<b>Exterior Finish</b>	<b>Highly Visible Yellow</b>
<b>Compass Safe Distance</b>	<b>Standard Magnetic – 0.60m Steering Magnetic – 0.40m</b>

## **PHYSICAL**

---

<b>Max Diameter (Main Body )</b>	<b>70 mm</b>
<b>Length (Main Body)</b>	<b>300 mm</b>
<b>Weight (Main Body)</b>	<b>283g (Battery included)</b>
<b>Length (Pole)</b>	<b>1050mm (Extended)</b>
<b>Weight (Pole)</b>	<b>300g</b>
<b>Weight (Storage Package)</b>	<b>1.08kg</b>



## 5.2 Dimensions

### PLOMO-500 Front View

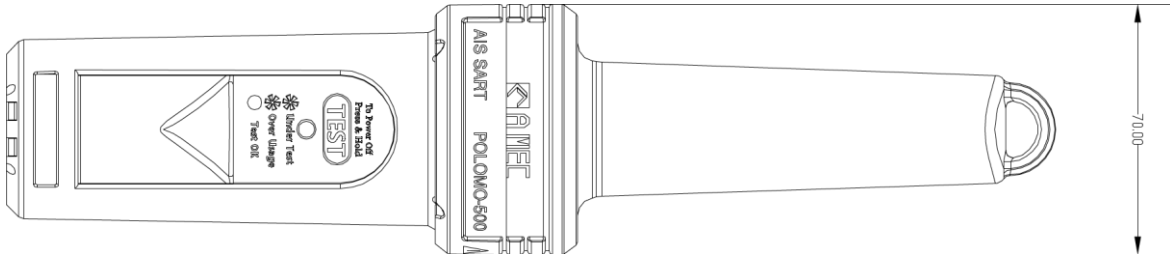

Figure 5-2-1 PLOMO-500 front view

### PLOMO-500 Side View

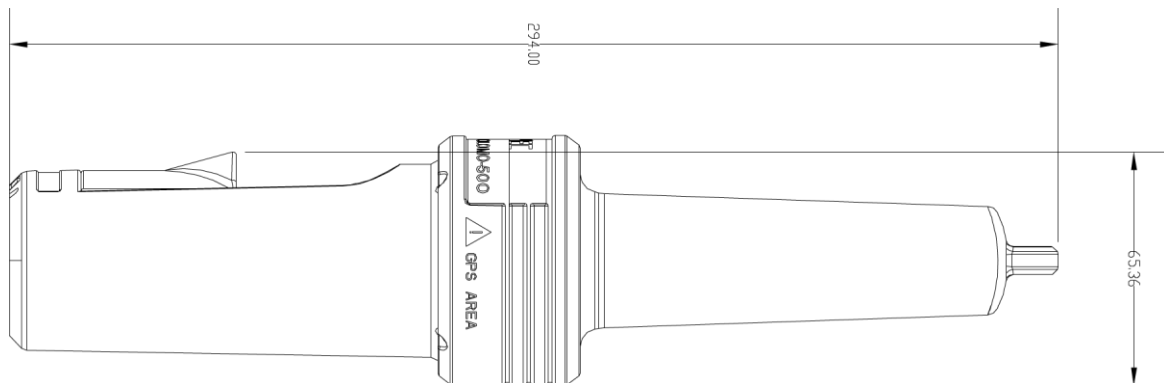

Figure 5-2-2 PLOMO-500 side view

### Pole Front View

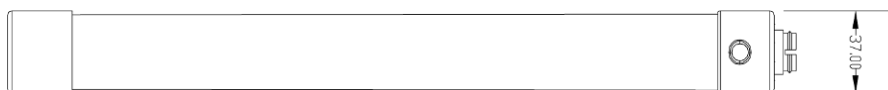
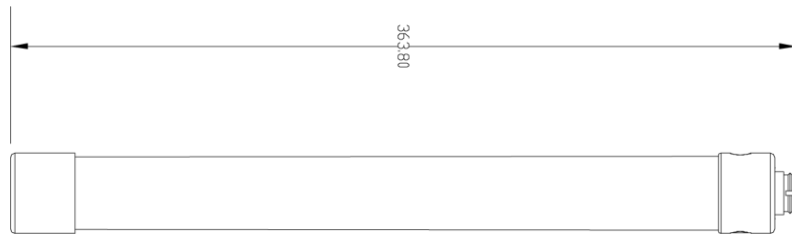

Figure 5-2-3 PLOMO-500 pole front view

**Pole Side View**



**Figure 5-2-4 PLOMO-500 pole side view**

**Bag Front View**



**Figure 5-2-5 PLOMO-500 bag side view**

**Bag Side View**



**Figure 5-2-6 PLOMO-500 bag side view**



## 6 AMEC WORLDWIDE WARRANTY

### Limited warranty

Subject to the terms, conditions and limitations set forth in this Worldwide Limited Warranty (hereinafter the “Warranty”), AMEC warrants that its products, when properly installed and used, will be free from defects in material and workmanship for a period of twelve (12) months, from the date of first purchase (the ‘Warranty Period’).

For the purposes of this warranty, ‘date of first purchase’ means the date that the product was purchased by the first retail customer, or by the institutional customer, or in the case of a product installed on a new vessel or any other marine related platform by a certified AMEC original equipment manufacturer (a ‘AMEC OEM’), the date that such vessel was purchased by the first retail customer.

AMEC will, at its sole option, repair or replace any defective products or components returned during the Warranty Period in accordance with the terms, conditions and limitations set forth below. **Such repairs or replacement will be the sole remedy of the customer under this Warranty.**

### Standard Warranty Service

To qualify for standard warranty service the product must be returned to a AMEC-certified service agent (i) within the Warranty Period, and (ii) within thirty (30) days of the alleged product failure. Any products returned must be securely packaged and sent pre-paid and insured to AMEC or to a AMEC-certified service agent. All products returned must be accompanied by a copy of the original sales receipt to be eligible for standard warranty service.

### Obtaining Warranty Service

A list of AMEC-certified service agents is available from AMEC Technical Support at [www.alltekmarine.com](http://www.alltekmarine.com)

### Other conditions

This Warranty is fully transferable provided that you furnish the original proof of purchase to the AMEC -certified service agent. This Warranty is void if the label bearing the serial number has been removed or defaced.

### Limitation and Exclusions

In addition to any other limitations and exclusions set forth herein, AMEC is not responsible for, and this Warranty does not cover:

- Failure due to abuse, misuse, accident, unauthorized alteration, modification or repair,



improper installation or operation (whether or not by a AMEC-certified service agent) or improper storage, shipping damage or corrosion;

- Costs associated with routine system checkouts, alignment/calibration, sea trials or commissioning;
- Defects or damage that result from the use of non-AMEC branded or certified products, accessories or other peripheral equipment, including without limitation housings, parts, or software;
- Aftermarket software (i.e. all software other than the original operating software sold with the products);
- Products that have been refurbished, reconditioned, or remanufactured (The foregoing does not apply to products repaired or replaced pursuant to the terms of this Warranty).
- Products that have been dismantled resulting in the broken label on the Products;
- costs associated with overtime or premium labor costs;
- differences in material, coloring or size that may exist between actual products and the pictures or descriptions of such products in our advertising, advertising literature or on the Internet;

**TO THE EXTENT PERMITTED BY APPLICABLE LAW, THE FOREGOING WARRANTY IS AMEC'S SOLE WARRANTY AND IS APPLICABLE ONLY TO NEW PRODUCTS PURCHASED WORLDWIDE.** THE PROVISIONS OF THIS WARRANTY ARE IN LIEU OF ANY OTHER WRITTEN WARRANTY, WHETHER EXPRESSED OR IMPLIED, WRITTEN OR ORAL, INCLUDING ANY WARRANTY OF MERCHANTABILITY OR FITNESS FOR A PARTICULAR PURPOSE.

THE LIABILITY OF AMEC TO A CUSTOMER UNDER THIS WARRANTY, WHETHER FOR BREACH OF CONTRACT, TORT, BREACH OF STATUTORY DUTY OR OTHERWISE SHALL IN NO EVENT EXCEED AN AMOUNT EQUAL TO THE TOTAL PURCHASE PRICE OF THE PRODUCT GIVING RISE TO SUCH LIABILITY AND IN NO EVENT SHALL AMEC BE LIABLE FOR SPECIAL, INCIDENTAL, CONSEQUENTIAL OR INDIRECT DAMAGES OR LOSS OF GOODWILL, REPUTATION, LOSS OF OPPORTUNITY OR INFORMATION, DATA, SOFTWARE OR APPLICATIONS.

SOME JURISDICTIONS DO NOT ALLOW EXCLUSION OR LIMITATION OF INCIDENTAL OR CONSEQUENTIAL DAMAGES SO THE ABOVE LIMITATIONS OR EXCLUSIONS MAY NOT APPLY TO YOU. THIS WARRANTY GIVES YOU SPECIFIC LEGAL RIGHTS AND YOU MAY ALSO HAVE OTHER RIGHTS, WHICH VARY FROM JURISDICTION TO JURISDICTION.

This Warranty supersedes and replaces all previous Warranties.



In the event that any term or provision contained in this Warranty is found to be invalid, illegal or unenforceable by a court of competent jurisdiction, then such provision shall be deemed modified to the extent necessary to make such provision enforceable by such court, taking into account the intent of the parties.

No oral or written representations made by AMEC or any seller, reseller or distributor of the products, including employees and agents thereof, shall create any additional warranty obligations, increase the scope, or otherwise modify in any manner the terms of this Warranty.

All AMEC products sold or provided hereunder are merely aids to navigation. It is the responsibility of the user to exercise discretion and proper navigational skill independent of any AMEC product.

## **7 DECLARATION OF CONFORMITY**

Hereby, Alltek Marine Electronics Corp. (AMEC) declares that this PLOMO-500 is in compliance with the essential requirements and other relevant provisions of Directive 1999/5/EC.

**Alltek Marine Electronics Corporation**

14F-2, No. 237, Sec. 1, Datong Rd.,  
Xizhi Dist., New Taipei City, 22161, Taiwan

Tel: +886 2 8691 8568

Fax: +886 2 8691 9569

Email: [service@alltekmarine.com](mailto:service@alltekmarine.com)

Website: [www.alltekmarine.com](http://www.alltekmarine.com)