



# CUBO-162

▶ AIS/VHF Antenna Splitter ◀

## USER MANUAL



**Automatic Identification System**



## **COPYRIGHT**

The entire contents of this instruction manual, including any future updates, revisions, and modifications, shall remain the property of AMEC at all times. Unauthorized copies or reproduction of this manual, either in part or whole, in any form of print and electronic media, is prohibited. The contents herein can only be used for the intended purpose of this manual.

## **DISCLAIMER**

AMEC is devoted to publish and maintain this product manual. As we continue to improve our AIS products to satisfy all customers' needs, information in this document is subject to change without notice. AMEC does not make any representations or warranties (implied or otherwise) regarding the accuracy and completeness of this document and shall in no event be liable for any loss of profit or any commercial damage, including but not limited to special, incidental, consequential, or other damage.

## WARNING!

**WARNING:** The AIS antenna splitter must be installed and operated in conformity with the provided instructions in the manual in order to maximize the device performance.

**WARNING:** The device should be used only together with an approved AIS transponder or receiver.

**WARNING:** DO NOT DISASSEMBLE OR MODIFY THE EQUIPMENT. Improper disassembly or modification could cause personal injury and will invalidate the guarantee.

**WARNING:** While most of the installation can be performed by the owner or the crew, a final commissioning can be done by your local agent/dealer when needed or required. AMEC and the local agent/dealer will not bear any responsibilities over any damages resulted from improper installation by unauthorized agent/dealer.

## **FOREWORD**

AMEC thanks you for the purchase of your new CUBO-162 AIS antenna splitter.

CUBO-162 is strictly tested at the factory to meet the rigorous demands of the marine environment. With proper installation, operation and maintenance, the equipment will serve loyally and reliably at its optimum.

For sales, services, and technical supports, please contact your local AMEC representatives or Alltek Marine Electronics Corp at [sales@alltekmarine.com](mailto:sales@alltekmarine.com) or [service@alltekmarine.com](mailto:service@alltekmarine.com). You are always welcome to visit our website at [www.alltekmarine.com](http://www.alltekmarine.com) for new product status and company update.

Thank you again. Be safe.

# TABLE OF CONTENT

<b>1</b>	<b>SYSTEM OVERVIEW</b> .....	<b>7</b>
<b>1</b>	<b>SYSTEM OVERVIEW</b> .....	<b>7</b>
1.1	PRODUCT DESCRIPTION .....	7
1.2	EQUIPMENTS IN THE BOX .....	8
1.3	EXTERNAL CONNECTIONS .....	9
1.4	WHAT IS AIS? .....	10
<b>2</b>	<b>INSTALLATION</b> .....	<b>12</b>
2.1	INSTALLATION PROCEDURES .....	12
2.2	MOUNTING TRANSPONDER MAIN UNIT .....	13
2.3	FM RADIO AND POWER SUPPLY CONNECTION .....	16
<b>3</b>	<b>GET STARTED</b> .....	<b>17</b>
3.1	START UP THE TRANSPONDER .....	17
3.2	LED INDICATORS .....	17
<b>4</b>	<b>SPECIFICATIONS</b> .....	<b>18</b>
4.1	PRODUCT SPECIFICATIONS .....	18
4.2	DIMENSIONS .....	20
<b>5</b>	<b>TROUBLESHOOTING</b> .....	<b>21</b>
	<b>FCC INTERFERENCE STATEMENT</b> .....	<b>22</b>
	<b>RF EXPOSURE WARNING</b> .....	<b>23</b>
	<b>DECLARATION OF CONFORMITY</b> .....	<b>24</b>
	<b>AMEC WORLDWIDE WARRANTY</b> .....	<b>24</b>

# 1 System Overview

## 1.1 Product Description

CUBO-162 is AMEC's latest AIS antenna splitter used to share a single VHF antenna for both VHF radio and AIS transponder or receiver. It's a further development of its predecessor CUBO-161 featuring lower insertion loss on transmission path and lower power consumption.

The splitter is designed to have zero insertion loss on reception. It's fail-safe feature guarantees priority to VHF radio operation even if the splitter has power outage. The built-in test function gives a simple diagnosis in the event of antenna problem. It provides also a feed for FM radio.

Featured with durable design and compact housing, the CUBO-162 is the best companion of your AIS transponder and receiver.

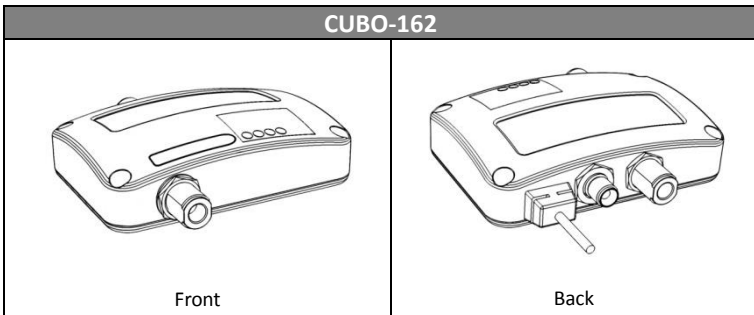

## 1.2 Equipments in the Box

Upon receiving the product please verify items in the box. If any is missing, please contact your local AMEC representative immediately.



AIS Antenna Splitter Unit

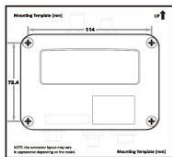

Mounting Template



M3.5x25 Screws



User Manual



AIS Transponder Connector Cable  
(BNC-PL259)



VHF Radio Connector Cable  
(PL259-PL259)



## 1.3 External Connections

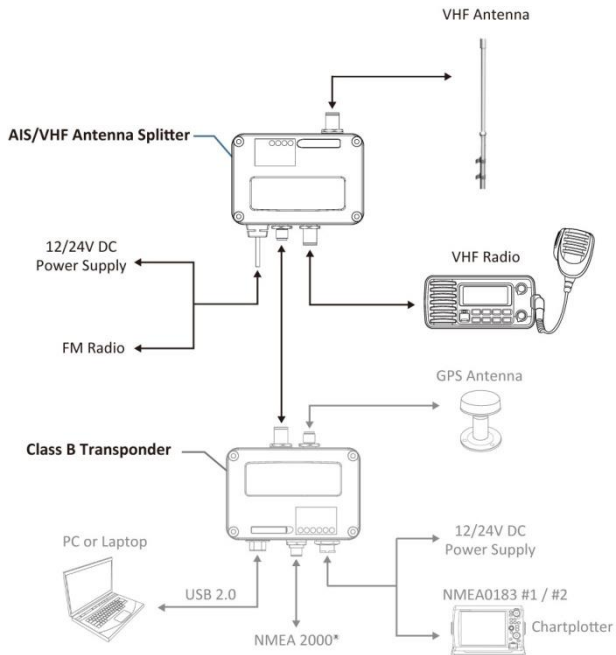

## 1.4 What is AIS?

The Automatic Identification System (AIS) is a Very High Frequency (VHF) radio broadcasting system that transfers packets of data over the VHF data link (VDL) and enables AIS equipped vessels and shore-based stations to exchange identification information and navigational data. Ships with AIS transponders continually transmit their ID, position, course, speed and other data to all nearby ships and shore stations. Such information can aid greatly in situational awareness and provide a means to assist in collision avoidance.

AIS equipment is standardized by ITU, IEC, IALA and IMO and is subject to approval by a certification body. The following AIS devices have been developed for variant applications.

- **AIS Class A:**

mandated by the IMO for vessels of 300 gross tonnages and upwards engaged on international voyages, cargo ships of 500 gross tonnages and upwards, as well as passenger ships. It transmits typically on 12.5 watt output power.

- **AIS Class B:**

provides limited functionality and is intended for non-SOLAS commercial vessels and recreational vessels. It transmits typically on 2 watt output power.

- **AIS Receiver**

only receives AIS signals from AIS class A, class B, AtoN and base station and does not have transmitter to send out AIS signal.

- **AIS Base Station:**

is provided by aids-to-navigation authorities to enable the ship to shore / shore to ship transmission of information. Networked AIS Base Stations can assist in providing overall maritime domain awareness.

- **AIS AtoN (Aids to Navigation):**

provides an opportunity to transmit position and status of buoys and lights through the same VDL, which can then show up on AIS-ready devices within the range.

- **AIS SART:**

Search and Rescue Transmitter using AIS can be used to assist in determining the location of a vessel in distress. It is typically used on life rafts.

## 2 Installation

### 2.1 Installation Procedures

Please familiarize the manual content before begin installation. Depending on your hardware configuration, use the following recommended steps for installation.

- 1) Mount the splitter unit to an appropriate location
- 2) Connect the VHF antenna
- 3) Connect the VHF radio
- 4) Connect your AIS device
- 5) Connect an optional FM radio and appropriate power source (12V / 24V DC, 2A)
- 6) Perform LED checking and system functional test after the device is powered on

## 2.2 Mounting Transponder Main Unit

The following guidelines should be noticed when selecting the environment to install your AMEC CUBO-162:

- Installation of the splitter should be undertaken in a safe environment without being exposed to any splashing water or rain.
- Do not install the AIS antenna splitter in a flammable or hazardous atmosphere.
- Keep adequate space around the AIS antenna splitter for routing of cables. See figure below for device dimensions.
- The safe distance of the splitter to any magnetic compass is at least 0.3m.
- The operating temperature is between  $-15^{\circ}\text{C}$  and  $+55^{\circ}\text{C}$ .
- The AIS antenna splitter can be installed and mounted on flat surface, or it can be mounted on wall with the four self tapping screws supplied.
- The device should be mounted in a location where the indicators can readily be observed as these indicators deliver relevant information on the status of the AIS antenna splitter.

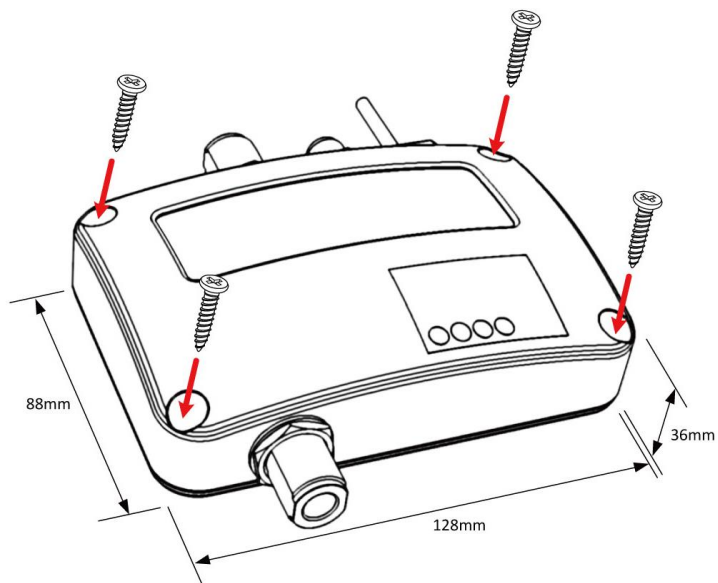

**Figure 1** Mounting the AIS antenna splitter

Use the attached cables to connect your VHF radio, VHF antenna and AIS transponder or receiver as illustrated below to ensure optimized performance:

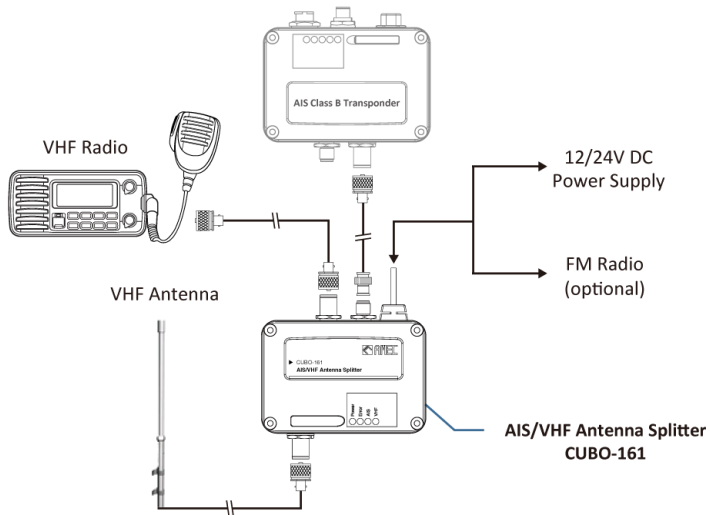

**Figure 2 Get your CUBO-162 connected**



When the antenna splitter is in use, ensure the splitter is connected both with VHF radio and AIS class B transponder/receiver. If you intend to connect the antenna splitter temporarily only to VHF radio or AIS class B transceiver/receiver, it's highly recommended to connect the unused connector to a dummy load which will protect the splitter from electrical damage.

## 2.3 FM Radio and Power Supply Connection

Practically, it is suggested to use the fuse panel before connecting directly to the battery/power supply. CUBO-162 requires a 12V or 24V power supply typically provided by the vessel's battery.

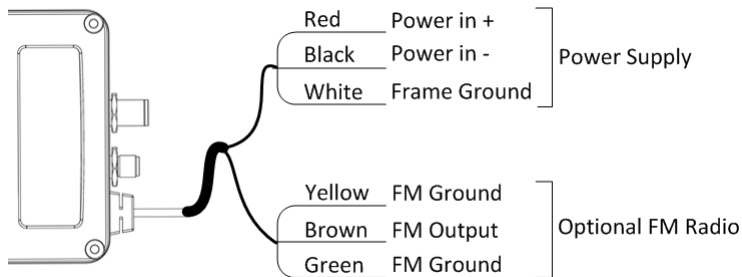

Figure 3 Wiring Instructions



## 3 GET STARTED

### 3.1 Start up the Transponder

The AIS antenna splitter will start up whenever the connected power source is ON. The operation status of the transponder can be checked from the LED lights on the unit. Description of the LED indications is provided in the following section. Please notice that VHF has priority when VHF radio and AIS transponder are transmitting at the same time.

### 3.2 LED Indicators

Indicator	Light	Description
Power	Green	The green LED indicates that the transponder has been powered up correctly.
Error	Red	The red LED illuminates when antenna has short or open circuit issue by VHF transmission at 25W.
AIS	Green	The AIS transponder is transmitting
VHF	Green	The VHF radio is transmitting

## 4 SPECIFICATIONS

### 4.1 Product Specifications

RF PERFORMANCE	
AIS & VHF Radio Frequency Range	156.025 MHz~162.025 MHz
Insertion loss, AIS Receive path	Typical 0dB
Insertion loss, VHF Radio Receive path	Typical 0dB
Insertion loss, AIS Transmit path	Typical 1dB
Insertion loss, VHF Radio Transmit path	Typical 1dB
POWER SUPPLY	
Supply Voltage	12V - 24V DC
Operating current (receive)	100mA typical at 12VDC
Operating current (transmit)	130mA typical at 12VDC
LED INDICATION	
One Power Indicator	Green
One Error Indicator	Red
One AIS Transponder Transmission Indicator	Green
One VHF Radio Transmission Indicator	Green

<b>PHYSICAL</b>	
Width	128 mm (5.51 inch)
Height	36 mm (1.97 inch)
Depth	88 mm (7.87 inch) (exclude connector)
Weight	230 g
AIS port	BNC : Max. 12.5W, 50Ω
VHF Radio port	SO-239 : Max. 25W, 50Ω
Antenna port	SO-239
FM Radio	Wiring connection
<b>ENVIRONMENT</b>	
Operating Temperature	-15°C~55°C
Storage Temperature	-25°C~70°C
Operating Humidity	95% RH at 40°C
Waterproof	IPX2

## 4.2 Dimensions

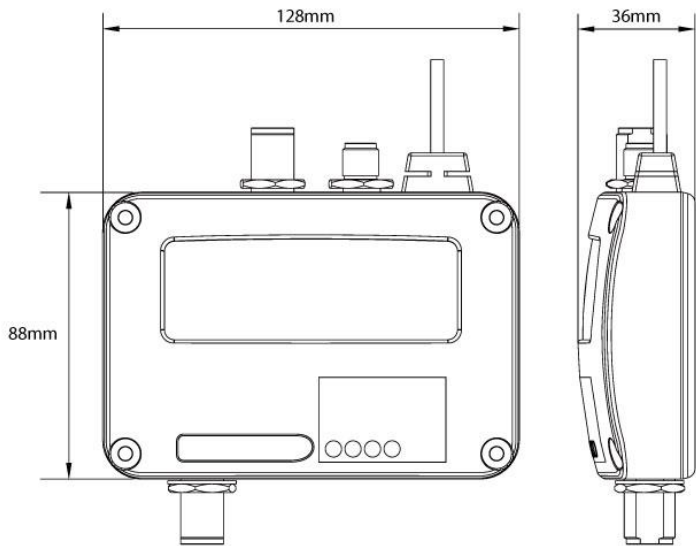

## 5 TROUBLESHOOTING

### **The AIS transponder is transmitting, but the “AIS” LED is not illuminated, why?**

Please check whether VHF radio is transmitting. When someone is talking on your VHF radio, AIS transponder will wait and not transmit.

### **The “Error” LED is lighting, what to do?**

The “Error” LED gives a first diagnosis about eventual problems with antenna. Please check if the VHF antenna is correctly connected with the splitter and ensure that the cable is intact and routed correctly. When needed, please contact your antenna supplier for further assistance.

### **The “VHF” LED not lighting when VHF radio is transmitting.**

Check the antenna output of the VHF radio is correctly connected to the antenna splitter input.

### **The “AIS” LED not lighting when AIS transceiver is transmitting.**

Check the antenna output of the AIS transponder is correctly connected to the antenna splitter input.

If you still encounter difficulties to set up or operate CUBO-162 correctly, please email to [service@alltekmarine.com](mailto:service@alltekmarine.com) for further instructions.

## **FCC INTERFERENCE STATEMENT**

NOTE: This equipment has been tested and found to comply with the limits for a Class A digital device, pursuant to part 15 of the FCC Rules. These limits are designed to provide reasonable protection against harmful interference when the equipment is operated in a commercial environment. This equipment generates, uses, and can radiate radio frequency energy and, if not installed and used in accordance with the instruction manual, may cause harmful interference to radio communications. Operation of this equipment in a residential area is likely to cause harmful interference in which case the user will be required to correct the interference at his own expense.

This device complies with Part 15 of the FCC Rules. Operation is subject to the following two conditions:

- 1) This device may not cause harmful interference, and
- 2) This device must accept any interference received, including interference that may cause undesired operation.

Any changes or modifications not expressly approved by AMEC for compliance could void of the user's authority to operate the equipment.

## RF Exposure Warning

**WARNING:** This device generates and radiates RF electromagnetic energy and must be installed and operated according to the instructions contained in this manual. Failure to do so may result in product malfunction and/or exposure to potentially harmful levels of radio frequency radiation.

**WARNING:** Never operate this device unless it is properly connected to a VHF antenna. To maximize performance and minimize human exposure to RF energy, always mount the antenna at least 3m from the device.

The system has a Maximum Permissible Exposure (MPE) radius of 60cm from the antenna. This has been determined assuming the maximum power of the transmitter and using a standard half-wave monopole VHF antenna with a maximum gain of 3dBi and termination impedance of 50 ohms.

When installing the antenna and operating the equipment consider the following:

- The antenna should be mounted at a minimum vertical distance of 5m above the deck in order to meet international safety directives on Maximum Permissible Exposure (MPE). Failure to adhere to these limits could expose persons within the 60cm radius to RF radiation in excess of the recommended MPE limits.
- Higher gain VHF antennas will require a larger MPE radius.
- Do not operate the unit when anyone is within the MPE radius of the antenna.
- The antenna should not be co-located or operated in conjunction with any other transmitting antenna.

# DECLARATION OF CONFORMITY

Hereby, Alltek Marine Electronics Corp. (AMEC) declares that this CAMINO-108 is in compliance with the essential requirements and other relevant provisions of Directive 1999/5/EC.

## AMEC WORLDWIDE WARRANTY

### Limited warranty

Subject to the terms, conditions and limitations set forth in this Worldwide Limited Warranty (hereinafter the “Warranty”), AMEC warrants that its products, when properly installed and used, will be free from defects in material and workmanship for a period of twelve (12) months, from the date of first purchase (the ‘Warranty Period’)

For the purposes of this warranty, ‘date of first purchase’ means the date that the product was purchased by the first retail customer, or by the institutional customer, or in the case of a product installed on a new vessel or any other marine related platform by a certified AMEC original equipment manufacturer (a ‘AMEC OEM’), the date that such vessel was purchased by the first retail customer.

AMEC will, at its sole option, repair or replace any defective products or components returned during the Warranty Period in accordance with the terms, conditions and limitations set forth below. Such repairs or replacement will be the sole remedy of the customer under this Warranty.

### Standard Warranty Service

To qualify for standard warranty service the product must be returned to a AMEC-certified service agent (i) within the Warranty Period, and (ii) within thirty (30) days of the alleged product failure. Any products returned must be securely packaged and



sent pre-paid and insured to AMEC or to a AMEC-certified service agent. All products returned must be accompanied by a copy of the original sales receipt to be eligible for standard warranty service.

### **Other conditions**

This Warranty is fully transferable provided that you furnish the original proof of purchase to the AMEC -certified service agent. This Warranty is void if the seal label is removed or defaced.

THE LIABILITY OF AMEC TO A CUSTOMER UNDER THIS WARRANTY, WHETHER FOR BREACH OF CONTRACT, TORT, BREACH OF STATUTORY DUTY OR OTHERWISE SHALL IN NO EVENT EXCEED AN AMOUNT EQUAL TO THE TOTAL PURCHASE PRICE OF THE PRODUCT GIVING RISE TO SUCH LIABILITY AND IN NO EVENT SHALL AMEC BE LIABLE FOR SPECIAL, INCIDENTAL, CONSEQUENTIAL OR INDIRECT DAMAGES OR LOSS OF GOODWILL, REPUTATION, LOSS OF OPPORTUNITY OR INFORMATION, DATA, SOFTWARE OR APPLICATIONS.

In the event that any term or provision contained in this Warranty is found to be invalid, illegal or unenforceable by a court of competent jurisdiction, then such provision shall be deemed modified to the extent necessary to make such provision enforceable by such court, taking into account the intent of the parties.

All AMEC products sold or provided hereunder are merely aids to navigation. It is the responsibility of the user to exercise discretion and proper navigational skill independent of any AMEC product.

**Alltek Marine Electronics Corporation**

14F-2, No. 237, Sec. 1, Datong Rd.,  
Xizhi Dist., New Taipei City, 22161, Taiwan

Tel: +886 2 2627 1599

Fax: +886 2 2627 1600

Email: [service@alltekmarine.com](mailto:service@alltekmarine.com)

Website: [www.alltekmarine.com](http://www.alltekmarine.com)